

Thermally Induced 2E Decay Pathways in Chromium(III) Complexes[†]Leslie S. Forster,* Douglas Murrow, and Anthony F. Fucaloro[‡]

Received November 29, 1989

The temperature dependence of ${}^2E \Rightarrow {}^4A_2$ decays has been determined for Cr(III) complexes with varying 4T_2 - 2E gaps in several solvents. At sufficiently low temperatures in a rigid medium, the decay is exponential. Nonexponentiality at higher temperatures is strong evidence that ${}^2E \Rightarrow {}^4T_2$ back-transfer is a significant pathway for 2E depopulation, when photolysis is inhibited by low temperatures or low solvent mobility.

Introduction

In the overwhelming majority of Cr(III) complexes, emission occurs from 2E , the lowest excited level (Figure 1). At low temperatures, radiative (k_r) and nonradiative (k_{nr}°) ${}^2E \Rightarrow {}^4A_2$ processes comprise the photophysical pathways for return to the ground state. As the temperature is increased, the 2E lifetime decreases and the nature of the temperature-dependent processes that depopulate 2E has been the subject of continuing interest.¹⁻⁸ Possibilities include thermally enhanced nonradiative ${}^2E \Rightarrow {}^4A_2$ decay ($k_{nr}(T)$), ${}^2E \Rightarrow {}^4T_2$ back-transfer (k_{bisc}), and chemical reaction (k_{reacn}). For simplicity, we do not consider 2E depopulation via 2T_1 as a separate process.

Possible contributions of back-transfer to the 2E decay have been inferred indirectly. In one study the decay rates of a group of complexes with varying 4T_2 - 2E separations were recorded at 25 °C.¹ There was an indication that the shorter lifetimes were correlated with the smaller 4T_2 - 2E gaps. In subsequent work, the activation energies for thermal quenching in a small range close to ambient temperatures were determined and compared to calculated 4T_2 - 2E energy differences.² This led to the generalization that back-transfer is important only when the 4T_2 - 2E gap does not exceed 30-35 kJ mol⁻¹. Endicott and co-workers have recently examined the thermal quenching of the 2E lifetime over a wider range of temperatures.⁹ In these studies, estimation of the 4T_2 - 2E gap was crucial; when the activation energy was less than the minimum calculated energy gap, back-transfer was ruled out. The energy gap calculation is subject to some uncertainty, and there are many cases where a firm conclusion is not possible.

Cr(CN)₆³⁻ is a complex with a large 4T_2 - 2E gap, and back-transfer is not likely at ambient or lower temperatures. The 2E decay in this complex is highly exponential in both rigid and fluid media.⁷ In contrast, the 4T_2 - 2E gap is small in Cr(urea)₆³⁺ and the excited-state decay is nonexponential in a glassy solution at 77 K.¹⁰ Cr(urea)₆³⁺ is the classic example of back-transfer—the intensity of delayed ${}^4T_2 \Rightarrow {}^4A_2$ emission grows relative to the ${}^2E \Rightarrow {}^4A_2$ emission as the temperature is elevated.¹¹

In Cr(NH₃)_{6-n}(H₂O)_n³⁺ complexes, the 4T_2 - 2E gap decreases progressively as n increases. When $n = 5$ or 6, the 2E decay is nonexponential at 77 K but is exponential when $n = 0-4$.¹² However, as the temperature is increased in Cr(NH₃)₄(H₂O)₂³⁺ solutions, the decay becomes progressively more nonexponential. Since the magnitude of the 4T_2 - 2E gap determines the contribution of ${}^2E \Rightarrow {}^4T_2$ back-transfer to the decay rate at any temperature, it was suggested that the nonexponentiality was due to back-transfer.

We now demonstrate that thermally induced changes in exponentiality can, in favorable circumstances, be used as an alternative method for distinguishing back-transfer from other thermal relaxation channels.

Experimental Section

Cr(en)₃Cl₃ was prepared by a standard method.¹³ Cr(ox)₃³⁻ was obtained by dissolving Cr³⁺:NaMgAl(ox)₃·9H₂O (3 mol % Cr)¹⁴ in water.

* Abbreviations: acac = 2,4-pentanedionato, en = 1,2-diaminoethane, ox = oxalato, cyclam = 1,4,8,11-tetraazacyclotetradecane, bpy = 2,2'-bipyridine, EGW = ethylene glycol/H₂O (2:1 v/v).

[‡] Permanent address: Joint Science Department, Claremont Colleges, Claremont, CA 91711.

[Cr(CH₃NH₂)₅Cl]Cl₂ was prepared by A. M. Ghaith in this laboratory by a literature method.¹⁵ Samples of Cr(en)₂(ox)Cl and KCr(en)(ox)₂ were generously provided by O. Mønsted of the University of Copenhagen. All of the absorption spectra agreed well with the published spectra.

Solutions were cooled by immersion in liquid N₂ or by a stream of cooled N₂ directed onto the cuvette. Whenever the decay time was sensitive to temperature, care was taken to establish thermal uniformity through the entire sample volume. Radiation of 337 nm from a N₂ laser was used for excitation. The emission was passed through filters and a 0.25-m monochromator onto a Hamamatsu R943-02 photomultiplier. The photocurrent was digitized by a Biomation 805 transient recorder, and 100 pulses were averaged by a microcomputer. Time-resolved spectra were recorded by means of a boxcar integrator.

Results and Discussion

Kinetic Analysis. The decay profile for emission from a collection of excited molecules following pulsed excitation can be represented by a sum of exponentials:

$$I(t) = \sum a_i \exp(-t/\tau_i) \quad (1)$$

In general, the overall decay rate for the i th species is, to a good approximation⁶

$$\tau_i^{-1} = (k_r + k_{nr}^\circ + k_{nr}(T) + (1 - \eta_{isc})k_{bisc} + k_{reacn})_i \quad (2)$$

η_{isc} is the efficiency of populating 2E from thermally equilibrated 4T_2 . When a single chemical species is in a unique environment, the decay is exponential and the thermal decay component is

$$\tau^{-1} - \tau_0^{-1} = k_{nr}(T) + (1 - \eta_{isc})k_{bisc} + k_{reacn} \quad (3)$$

It is usual to represent the temperature dependence of the thermal decay, as extracted from eq 3, by a multiterm Arrhenius function:

$$\tau^{-1} - \tau_0^{-1} = \sum A_i \exp(-E_i/RT) \quad (4)$$

Both the 2E and 4A_2 levels are derived from the t_2^3 configuration, and the ${}^2E \Rightarrow {}^4A_2$ spectra indicate very little geometry change between the two levels. In consequence, when $k_{bisc} = k_{reacn} = 0$, the τ_i are the same in all solvent environments and the decay is exponential. The broad absorption spectra associated with ${}^4T_2 \Leftarrow {}^4A_2$ transitions point to a substantial geometry change in the 4T_2 level, which is derived from t_2^2e . This leads to a dependence of the 4T_2 energy upon the arrangement of the solvent molecules

- Linck, N. J.; Berens, S. J.; Magde, D.; Linck, R. G. *J. Phys. Chem.* **1983**, *87*, 1733.
- Rojas, G.; Magde, D. *Inorg. Chem.* **1987**, *26*, 2334.
- Kane-Maguire, N. A. P.; Wallace, K. C.; Miller, D. B. *Inorg. Chem.* **1985**, *24*, 597.
- Endicott, J. F.; Ramasami, T.; Tamarasan, R.; Lessard, R. B.; Ryu, C. K.; Brubaker, G. R. *Coord. Chem. Rev.* **1987**, *77*, 1.
- Targos, W.; Forster, L. S. *J. Chem. Phys.* **1966**, *44*, 4342.
- Forster, L. S. *Chem. Rev.* **1990**, *90*, 331.
- Castelli, F.; Forster, L. S. *J. Am. Chem. Soc.* **1973**, *95*, 7223.
- Schmidtke, H.-H.; Biertumpel, I.; Degen, J. *Ber. Bunsen-Ges. Phys. Chem.* **1989**, *93*, 1485.
- Lessard, R. B.; Endicott, J. F.; Perkovic, M. W.; Ochrymowicz, L. A. *Inorg. Chem.* **1989**, *28*, 2574.
- Castelli, F.; Forster, L. S. *J. Am. Chem. Soc.* **1975**, *97*, 6306.
- Klassen, D. M.; Schäfer, H. L. *Ber. Bunsen-Ges. Phys. Chem.* **1968**, *72*, 663.
- Forster, L. S.; Rund, J. V.; Castelli, F.; Adams, P. *J. Phys. Chem.* **1982**, *86*, 2395.
- Rollinson, C. L.; Bailar, J. C., Jr. *Inorg. Synth.* **1946**, *2*, 199.
- Condrate, R. A.; Forster, L. S. *J. Mol. Spectrosc.* **1967**, *24*, 490.
- Rogers, A.; Staples, P. I. *J. Chem. Soc.* **1965**, 6834.

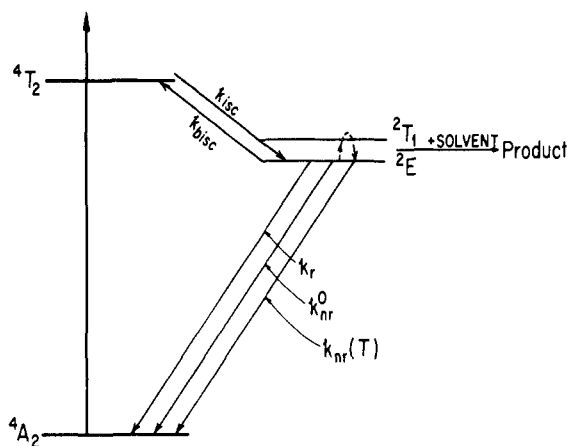

Figure 1. Energy levels and rate constants for Cr(III) complexes.

in the second coordination sphere. Since this arrangement will differ from one complex to another, a distribution of ⁴T₂-²E gaps will obtain at any instant. The effect of this distribution upon the ²E decay depends upon two parameters: (1) the magnitude of the ⁴T₂-²E gap relative to the thermal energy and (2) the relative rates of solvent motion and excited-state decay.

In a rigid noncrystalline solution, the environments are frozen-in during rapid cooling and solvent motion is negligible on the time scale of ²E decay. *k_{reacn}* is also negligible in a rigid medium, and the extent of nonexponentiality will depend only upon the variation of *k_{bisc}* among the several solvates. The ⁴T₂-²E gap is very sensitive to the ligands. When this gap is large compared to the thermal energy, back-transfer is not an important process for any solvate and the decay is exponential. As ⁴T₂ becomes thermally accessible, the effect of the differing ⁴T₂-²E gaps is manifested by nonexponential ²E decay.

At the other extreme, in low-viscosity fluids solvent motion is fast compared to ²E decay. Each excited complex will then sample the entire range of solvent environments, and the ²E decay will be exponential whether or not back-transfer is important. This conclusion is not changed if *k_{reacn}* ≠ 0.

In the domain where neither of the two extremes obtains, the situation is a bit more complicated. As the temperature is increased, solvent mobility leads to solvate interconversion. The temperature region in which solvent motions compete with the excited-state decay depends upon the nature of the solvent. When the rates of solvent mobility and excited-state decay are comparable, back-transfer cannot be represented by a single rate constant. If the primary photolytic step requires solvent motion, *k_{reacn}* may also vary among the solvates. If neither *k_{bisc}* nor *k_{reacn}* is vanishingly small, the decay will then be nonexponential.

A detailed kinetic treatment of the excited-state decay as a function of temperature and solvent mobility is complicated by the multitude of solvates that are present. Many terms would be necessary in eq 1 to fit the decay accurately. The fluorescence decays of anilidonaphthalenesulfonates in a cyclodextrin have been modeled with the continuous lifetime distributions¹⁶ that have been suggested for heterogeneous environments.^{17,18} However, a two-species model

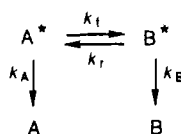

is mathematically tractable,¹⁹ and the actual solvate distribution can be regarded as a superposition of many two-species systems. The essential qualitative dependence of the decay profiles on

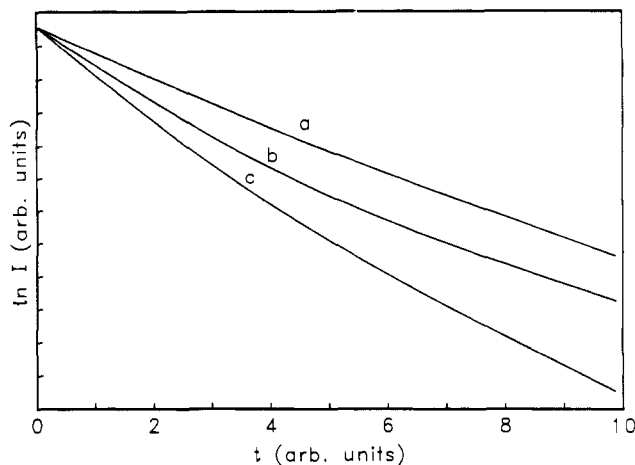

Figure 2. Two-species model simulations (based on eqs 5-7): (a) *k_A* = 2 × 10⁴, *k_B* = 1 × 10⁴, *k_f* = *k_r* = 0; (b) *k_A* = 4 × 10⁴, *k_B* = 1 × 10⁴, *k_f* = *k_r* = 0; (c) *k_A* = 6 × 10⁴, *k_B* = 1 × 10⁴, *k_f* = *k_r* = 1 × 10⁴. Equal populations of A* and B* at *t* = 0 are assumed.

temperature and solvent mobility is illustrated by this simplified approach. *k_A* and *k_B* are the decay rates of A* and B* in the absence of any interconversion between the two species and include back-transfer. *k_f* and *k_r* are the solvate interconversion rates, and they measure the fluctuation rate of the solvent environment. In this model, eq 1 reduces to

$$I(t) = a_1 \exp(-t/\tau_1) + a_2 \exp(-t/\tau_2) \quad (5)$$

with

$$\tau_{1,2}^{-1} = 0.5\{(k_A + k_f + k_B + k_r) \mp [(k_A + k_f - k_B - k_r)^2 + 4k_f k_r]^{1/2}\} \quad (6)$$

If the radiative rates and the initial concentrations of both species are equal

$$\begin{aligned}
 a_1 &= (2\tau_2^{-1} - k_A - k_B)/(\tau_2^{-1} - \tau_1^{-1}) \\
 a_2 &= (-2\tau_1^{-1} + k_A + k_B)/(\tau_2^{-1} - \tau_1^{-1}) \quad (7)
 \end{aligned}$$

In the limit of fast solvent motion, *k_f*, *k_r* ≫ *k_A*, *k_B*, the decay is exponential and the rate constant is a population weighted average of *k_A* and *k_B*:

$$\tau^{-1} = \frac{k_B + ([A^*]/[B^*])k_A}{1 + [A^*]/[B^*]} \quad (8)$$

If *k_B* remains small in a range where *k_A* is temperature dependent, increasing the temperature in a rigid medium (*k_f* = *k_r* = 0) leads to increasing nonexponentiality at short times but to little change at long times (Figure 2a,b). This would correspond to the case where the ⁴T₂-²E gap is small in A and large in B. As the solvent becomes mobile, *k_f* and *k_r* compete with decay and the overall decay rate increases (Figure 2c). At the same time, the nonexponentiality is reduced by solvent motion.

Criteria for Identifying ²E ⇒ ⁴T₂ Back-Transfer. The thermal enhancement of delayed fluorescence relative to phosphorescence is an unambiguous marker for back-transfer, and Cr(urea)₆³⁺ is the best example of this phenomenon. In crystalline Cr(urea)₆(ClO₄)₃, both the fluorescence and phosphorescence decays are exponential with the same lifetime, indicating a unique environment for all of the complexes.¹⁰ In a rigid alcohol-H₂O glass at 77 K, both emissions are nonexponential and the delayed fluorescence decays faster than the phosphorescence. This is consistent with a distribution of ⁴T₂-²E gaps in which complexes with the smallest gaps, and hence the largest back-transfer rates, are the dominant contributors to the fluorescence.

The absence of delayed fluorescence does not rule out back-transfer. ⁴T₂ and ²E are nearly equienergetic in Cr(D₂O)₆³⁺, yet the delayed fluorescence is barely detectable.²⁰ The ²E lifetime

(16) Bright, F. V.; Catena, G. C.; Huang, J. *J. Am. Chem. Soc.* **1990**, *112*, 1343.

(17) Alcalá, J. R.; Gratton, E.; Prendergast, F. G. *Biophys. J.* **1987**, *51*, 587.

(18) James, D. R.; Liu, Y. S.; De Mayo, P.; Ware, W. R. *Chem. Phys. Lett.* **1985**, *120*, 460.

(19) Kemp, T. J. *Prog. React. Kinet.* **1980**, *10*, 301.

(20) Camassei, F. D.; Forster, L. S. *J. Chem. Phys.* **1969**, *50*, 2603.

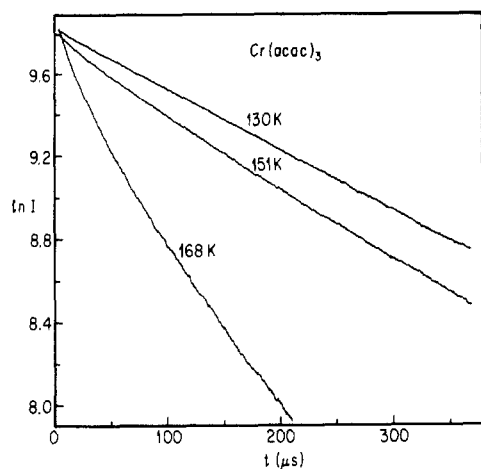

Figure 3. Emission decay from $\text{Cr}(\text{acac})_3$ in EGW.

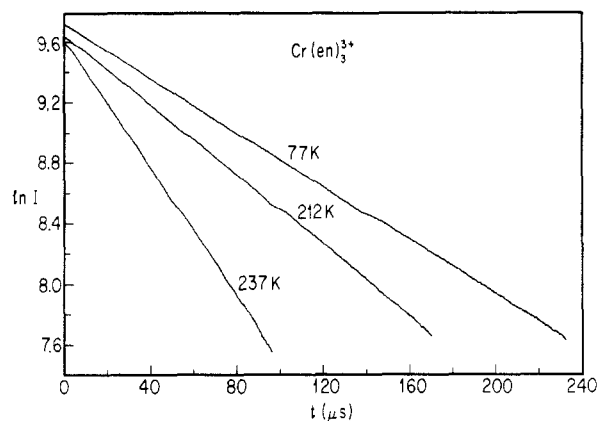

Figure 4. Emission decay from $\text{Cr}(\text{en})_3^{3+}$ in $\text{DMSO}/\text{H}_2\text{O}$ (1:1 v/v).

decrease in $\text{Cr}(\text{ox})_3^{3-}$ is not accompanied by any delayed fluorescence, but the ${}^4\text{T}_2\text{-}{}^2\text{E}$ gap is small enough in this complex to permit substantial back-transfer.²⁰

It is our hypothesis that in a rigid noncrystalline medium the ${}^2\text{E}$ decay will be exponential when the temperature is low enough to inhibit back-transfer. If the decay changes from exponential to nonexponential under conditions where no ${}^2\text{E}$ reaction occurs, back-transfer is established. For most $\text{Cr}(\text{III})$ complexes, 77 K is sufficiently low to achieve exponentiality in glassy matrices. $\text{Cr}(\text{urea})_6^{3+}$, $\text{Cr}(\text{D}_2\text{O})_6^{3+}$, and $\text{Cr}(\text{ox})_3^{3-}$ are exceptions to this generalization.

The behavior of $\text{Cr}(\text{acac})_3$ in EGW supports the hypothesis (Figure 3). Mobility of this solvent just begins to compete with excited-state decay on the 200- μs time scale at 150 K.²¹ The 450- μs $\text{Cr}(\text{acac})_3$ decay is very exponential at 130 K. Nonexponentiality, which is detectable below 150 K, becomes more pronounced as the temperature is increased. The $\text{Cr}(\text{acac})_3$ lifetime drop is very pronounced between 151 and 168 K. Although there is appreciable solvent motion in this range, it is doubtful if reaction is responsible for the accelerated ${}^2\text{E}$ decay. Back-transfer is the more likely source of the nonexponentiality.

$\text{Cr}(\text{en})_3^{3+}$ presents a contrasting picture. The ${}^4\text{T}_2\text{-}{}^2\text{E}$ gap is large in this complex, and the decay remains exponential as the lifetime is decreased (Figure 4). $\text{Cr}(\text{NH}_3)_5(\text{CN})^{2+}$ is another large-gap complex, and the same behavior prevails. It must be emphasized that the persistence of exponentiality in these two complexes does not, in itself, bear on the question of back-transfer, since the major lifetime decreases do not start until EGW is very fluid.

The ability to assess the extent of nonexponentiality depends upon the data quality. At one extreme are the time-correlated photon-counting lifetime measurements, where it is possible to

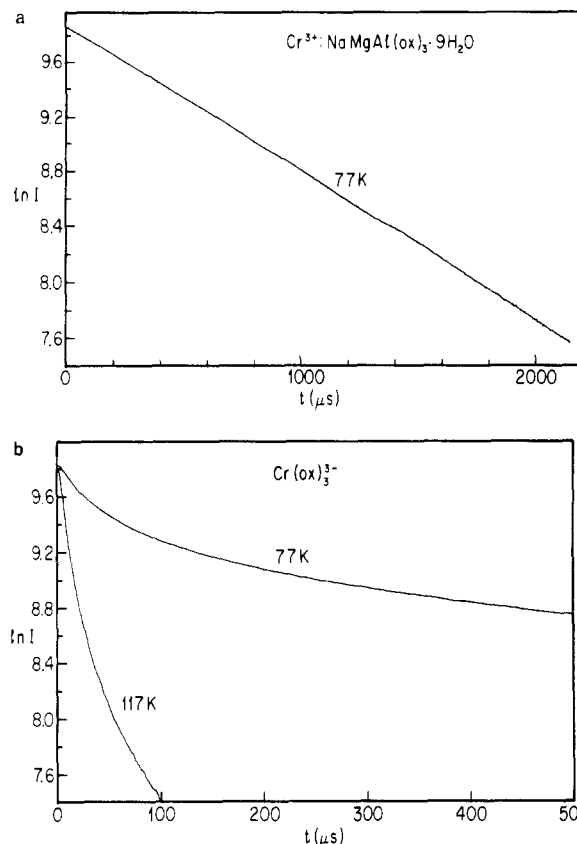

Figure 5. Decay of the emission from (a) $\text{Cr}_3^+:\text{NaMgAl}(\text{ox})_3 \cdot 9\text{H}_2\text{O}$ and (b) $\text{Cr}(\text{ox})_3^{3-}$ in $\text{DMSO}/\text{H}_2\text{O}$ (1:1 v/v).

fit up to four terms in eq 1, although a two- or three-term fit is more usual.²² The fitting is accomplished through a nonlinear least-squares procedure, and several tests for adequacy of fit have been employed. The other extreme involves recording an oscilloscope tracing of the emission excited by a single pulse. These data are then transferred to a photograph, and $\ln I$ is plotted against time. The widespread availability of fast A/D converters has led to the collection of data that are intermediate in quality. These data are sufficiently good to detect fairly small departures from exponentiality but do not permit the reliable extraction of the parameters in a multiexponential fit, unless the lifetimes are very different. Visual examination of the $\ln I$ vs t plot is all that is required to assess the extent of nonexponentiality for the purpose of assessing the thermal decay pathway.

The ${}^2\text{E} \Rightarrow {}^4\text{A}_2$ emission energy is not affected by solvent motion, and there are no time-dependent spectral shifts to introduce artifactual nonexponentiality.²³ Since instrumental errors, e.g., baseline variation and rf pickup, are present, we base all of our inferences on changes in the decay profile.

Impurity emission will also lead to nonexponentiality, even in fluid media. The impurity and genuine emission spectra are usually different, and time-resolved spectra will reveal impurities at levels sufficient to produce nonexponentiality. None of the results presented here are affected by impurity emission, according to this criterion. When the decay rate is sensitive to temperature, appreciable thermal gradients must be avoided. Localized heating can be minimized by defocusing the excitation beam.

${}^2\text{E}$ Decays from $\text{Cr}(\text{en})_{3-n}(\text{ox})_n^{3-2n}$ Complexes. The ${}^2\text{E}$ energies are nearly the same for the four complexes in this group, while the ${}^4\text{T}_2$ energy decreases progressively as n increases. Since the ${}^4\text{T}_2\text{-}{}^2\text{E}$ gap varies in a predictable way, these complexes permit testing of the basic method without the need to calculate precise values of this gap.

(21) Ghaith, A. M.; Forster, L. S.; Rund, J. V. *J. Phys. Chem.* **1988**, *92*, 6197.

(22) O'Connor, D. V.; Phillips, D. *Time Correlated Single Photon Counting*; Academic Press: London, 1984; Chapter 6.

(23) DeToma, R. P.; Easter, J. H.; Brand, L. *J. Am. Chem. Soc.* **1976**, *98*, 5001.

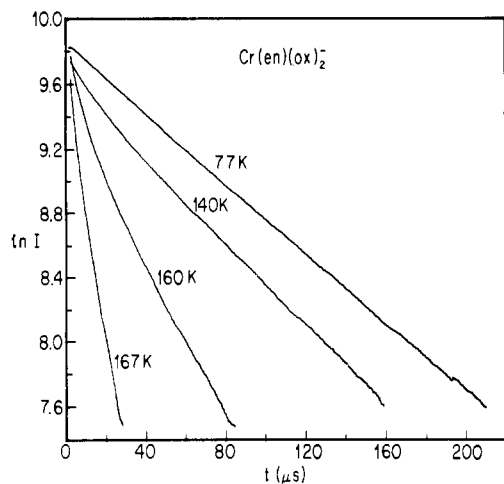

Figure 6. Emission decay from Cr(en)(ox)₂⁻ in DMSO/H₂O (1:1 v/v).

The ²E decays of Cr(ox)₃³⁻ in NaMgAl(ox)₃·9H₂O are exponential at 77 K and above (Figure 5a). The lifetime is 900 μs at 77 K and 105 μs at 128 K. The temperature dependence of the decay rate is well fitted by a single-term Arrhenius equation between 77 and 128 K with *E_a* = 1311 cm⁻¹ and *A* = 2 × 10¹⁰ s⁻¹. The ⁴T₂-²E separation can be estimated from the positions of the sharp ²E ⇒ ⁴A₂ emission and the band maximum of the broad ⁴T₂ ⇒ ⁴A₂ absorption band. Schläfer suggested that ⁴T₂ and ²E are nearly equienergetic when the difference between these two positions is approximately 2000 cm⁻¹.²⁴ The difference between the ⁴T₂ ⇒ ⁴A₂ absorption maximum and the ²E ⇒ ⁴A₂ origin in Cr³⁺:NaMgAl(ox)₃·9H₂O is 3200 cm⁻¹. Application of the Schläfer rule would then yield 1200 cm⁻¹ for the ⁴T₂-²E gap, Δ*E*. The facile thermal quenching and the good agreement between Δ*E* and *E_a* strongly implicate back-transfer as the dominant thermal decay process, in spite of the absence of delayed fluorescence.

The effect of environmental microheterogeneity is clearly illustrated by the emission of Cr(ox)₃³⁻ in a noncrystalline solution. In contrast to the case in the crystalline host, the decays in DMSO/H₂O and EGW are highly nonexponential in glassy environments at 77 K (Figure 5b); the lifetime approaches 900 μs only at times greater than 500 μs after excitation. The analogous behavior of Cr(urea)₆³⁺, where delayed fluorescence obtains, and Cr(ox)₃³⁻, where no fluorescence is detectable, again shows that back-transfer need not be accompanied by fluorescence.

The effect of temperature on the Cr(en)(ox)₂⁻ decays in DMSO/H₂O illustrates the effect of increasing the ⁴T₂-²E gap (Figure 6). The 77 K decay is now exponential, but nonexponentiality is evident at 140 K, where the solvent is still rigid. At long times the semilogarithmic profile at 140 K is nearly parallel to the 77 K line. This is reminiscent of the two-species simulation (Figure 2, curves a and b), where solvate interconversion is negligible, and exemplifies the typical temperature behavior in a range where the glass is still rigid. At higher temperature, the lifetime reduction is more pronounced and some solvate interconversion is probable at 160 K, even though the nonexponentiality persists.

The ⁴T₂-²E gap is further increased in Cr(en)₂(ox)⁺ and the decays remain exponential at all temperatures in DMSO/H₂O through a range where the lifetime reduction is marked (Figure 7a). The thermal decay component is well fitted by a single-term Arrhenius function from 168 to 189 K with *E_a* = 32 kJ mol⁻¹. Similar results obtain in EGW, although there is a hint of nonexponentiality at 176 K. On the basis of these data alone, no conclusion about the contribution of back-transfer to the thermal decay is possible. When the solvent is changed to neat glycerol (99.5%) (Figure 7b), which remains rigid at 211 K, the behavior parallels that of Cr(en)(ox)₂⁻ in EGW. Thus by increasing the

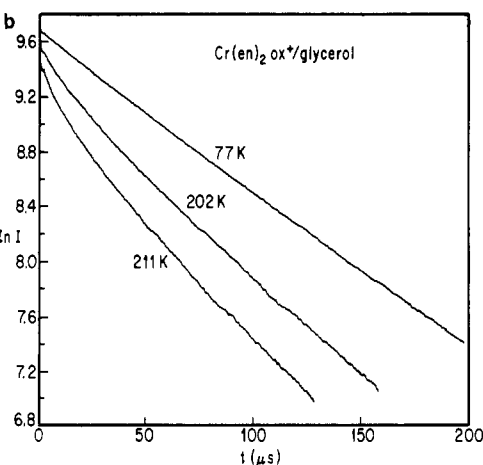
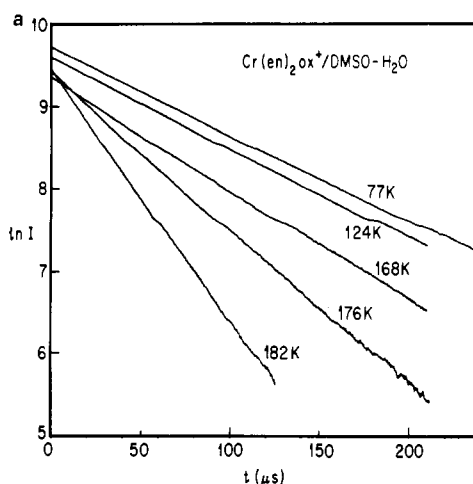

Figure 7. Emission decay from Cr(en)₂(ox)⁺: (a) DMSO/H₂O (1:1 v/v); (b) neat glycerol.

solvent viscosity, one can examine the behavior at higher temperatures while the environment is kept rigid. These results indicate that back-transfer contributes to the thermal decay above 200 K in Cr(en)₂(ox)⁺. In a fluid solvent, where the lifetime decrease begins at a lower temperature, another thermal relaxation pathway appears to be involved. This process, which is included in *k_{nr}*(*T*), is not affected by microenvironmental heterogeneity.

The Cr(en)₃³⁺ decays are exponential in all solvents, including neat glycerol. The lifetime decreases in DMSO/H₂O and EGW occur only after the solvent motions are faster than the ²E decay. Consequently, the persistence of exponentiality is not evidence for or against back-transfer as a decay pathway in these solvents. In neat glycerol, the lifetimes are 92 μs at 226 K and 81 μs at 236 K and the decays are very exponential at both temperatures. The time constants for rotational motions in pure glycerol vary from ≈10⁻³ s at 217 K to 10⁻⁶ s at 236 K.²⁵ The persistence of exponential decay in this solvent through a temperature domain where the decay rate increases, but where the glycerol motions are not fast on the excited-state time scale, indicates that back-transfer is not the dominant thermal decay process in Cr(en)₃³⁺.

Other Complexes. The ⁴T₂-²E gap is reduced by chloride substitution, and Endicott has suggested that back-transfer is a significant contributor to the thermal lifetime reduction in Cr(NH₃)₅Cl²⁺ in a noncrystalline host.⁹ If Cr(CH₃NH₂)₅Cl²⁺ is dissolved in EGW, the ²E decays are exponential at 77 K, but at 150 K some nonexponentiality is evident (Figure 8). The nonexponentiality increases progressively with temperature between 132 and 172 K. These results corroborate Endicott's interpretation. The ⁴T₂-²E gap is smaller in *cis*-Cr(cyclam)Cl₂⁺ than in Cr(CH₃NH₂)₅Cl²⁺, and the thermally induced nonexponentiality is easily discerned in this complex as well.

(24) Schläfer, H. L.; Gausmann, H.; Zander, H. U. *Inorg. Chem.* **1967**, *6*, 1528.

(25) Dux, H.; Dorfmueller, Th. *Chem. Phys.* **1979**, *40*, 219.

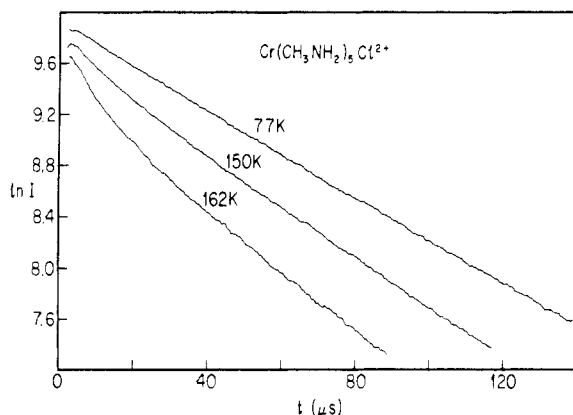

Figure 8. Emission decay from $\text{Cr}(\text{CH}_3\text{NH}_2)_5\text{Cl}_2^{2+}$ in EGW.

If this analysis is correct, the much reduced thermal quenching of $\text{Cr}^{3+}:\text{[Rh}(\text{NH}_3)_5\text{Cl]Cl}_2^9$ points to a much larger ${}^4\text{T}_2\text{-}^2\text{E}$ gap in the crystal than in a noncrystalline solution.

Nonexponential Decay and Arrhenius Plots. There are two problems associated with fitting the thermal component of the excited-state decay rate to an Arrhenius function (eq 4). In the first place, brute-force nonlinear least-squares fitting of multiexponential functions is notoriously difficult. High-quality data are required, and the data set must be highly overdetermined. If a single-exponential fit is adequate, the parameters can be reliably extracted. When the E_i are sufficiently different, the larger E_i in a double-exponential fit can also be estimated with some confidence, and in favorable cases all four of the parameters can be obtained.

A second complication is much more difficult to circumvent. What is to be done when the decay is nonexponential? One approach is to look for a linear tail in the semilog plot of the decay. If such linearity exists, it indicates a homogeneous emitting population with the smallest decay rate. The parameters extracted by an Arrhenius analysis of this tail decay rate could then be used to infer the intramolecular properties of the longest-lived fraction

of the emitters. However, interpretation of Arrhenius parameters in a temperature range where some of the decays are nonexponential carries a risk. The obvious departures from Arrhenius behavior of several $\text{Cr}(\text{NH}_3)_5\text{X}^{2+}$ complexes are likely due to the absence of a well-defined lifetime in certain temperature regions.⁹

Summary

The thermal decay behavior depends upon the interplay between the ${}^4\text{T}_2\text{-}^2\text{E}$ gap and the solvent mobility. For a given complex, the solvent mobility can be controlled, within limits, by an appropriate choice of solvent. The change in the character of the ${}^2\text{E}$ decay from exponential to nonexponential as the temperature is increased in solutions of Cr(III) complexes, where ${}^2\text{E}$ reaction is negligible, is direct evidence for the opening of a back-transfer thermal relaxation channel, even when delayed fluorescence is absent. ${}^2\text{E}$ reaction is usually suppressed in a rigid solvent.

Cr(III) complexes can be classified according to the solvent mobility that prevails when the large thermal enhancements of the decay rate begin. In one class, exemplified by $\text{Cr}(\text{acac})_3$ and $\text{Cr}(\text{en})_2(\text{ox})^+$, the increasing solvent mobility plays a role in the lifetime reduction. In complexes with a large ${}^4\text{T}_2\text{-}^2\text{E}$ gap, e.g., $\text{Cr}(\text{en})_3^{3+}$, *cis*- $\text{Cr}(\text{cyclam})(\text{NH}_3)_2^{3+}$, and $\text{Cr}(\text{bpy})_3^{3+}$, the major thermal decay processes begin only at temperatures where the solvent motions are already very fast. Whether the decay rate increase in the latter group is due to k_{reacn} or $k_{\text{nr}}(T)$ is not certain, but back-transfer is not the principal ${}^2\text{E}$ thermal decay pathway. Two thermally activated processes have been identified in fluid acetone solutions of $\text{Cr}(\text{NH}_3)_2(\text{NCS})_4^-$ and $\text{Cr}(\text{NCS})_6^{3-}$.²⁶

When nonexponential decay is present, care must be exercised in making inferences based upon parameters extracted from Arrhenius fits.

Acknowledgment. This work was supported by the donors of the Petroleum Research Fund, administered by the American Chemical Society, and by a grant to A.F.F. from Scripps College, one of the Claremont Colleges.

(26) Kang, Y. S.; Castelli, F.; Forster, L. S. *J. Phys. Chem.* **1979**, *83*, 2368.